

U.S. GOLD

JOHNNY
bazookatone™



3DO

© 1996 ARC Developments. Johnny Bazookatone is a trademark of U.S. GOLD, Inc., © 1996 U.S. GOLD, Inc. All Rights Reserved. Portions of this package design are © 1993 The 3DO Company. 3DO and the 3DO logos are trademarks and/or registered trademarks of The 3DO Company. 000500072



3DO

For use with 3DO™ systems

The 3DO Company shall not be liable to the end user for any loss of data, lost profits, cost of substitute goods or other consequential, incidental, special, punitive, or other damages of any kind arising out of the use of or inability to use the software.

The 3DO Company makes no warranties, express, implied or statutory, regarding the software, including without limitation the implied warranties of merchantability and fitness for any particular purpose, or any equivalent warranties under the laws of any jurisdiction.

Do not use a front or rear projection television with this product. Your projection television screen may be permanently damaged if stationary scenes or patterns are displayed on your projection television. Similar damage may occur if you place this product on hold or pause. If you use your projection television with this product, neither the 3DO Company nor U.S. Gold, Inc. will be liable for any resulting damage. This situation is not caused by a defect in this product or the 3DO system; other fixed or repetitive images may cause similar damage to a projection television. Please contact your TV manufacturer for further information.

The execution of software with the 3DO system involves the use of patent rights, granted or implied for, in certain countries. A purchaser of the 3DO system is licensed to use such patent rights with software licensed by the 3DO Company. No license, implied or otherwise, is granted for the execution of other software.

CONTENTS

STARTING UP	2
THE STORY	3
OPTIONS	7
CONTROLS	8
WORLDS	12
prison	12
hotel	13
restaurant	14
hospital	16
penthouse	17
GENERAL ITEMS	18
CREDITS	20

JOHANNY
bazookatone™

STARTING UP

- Turn on the power switch at the front of your 3DO Interactive Multiplayer™. The power light should come on.
- Press the open/close button to open the CD tray, place the Johnny Bazookatone CD in the tray (label up) and press the open/close button again to close the CD tray.
- After a few seconds the 3DO logo should appear on screen, followed by the title sequence.

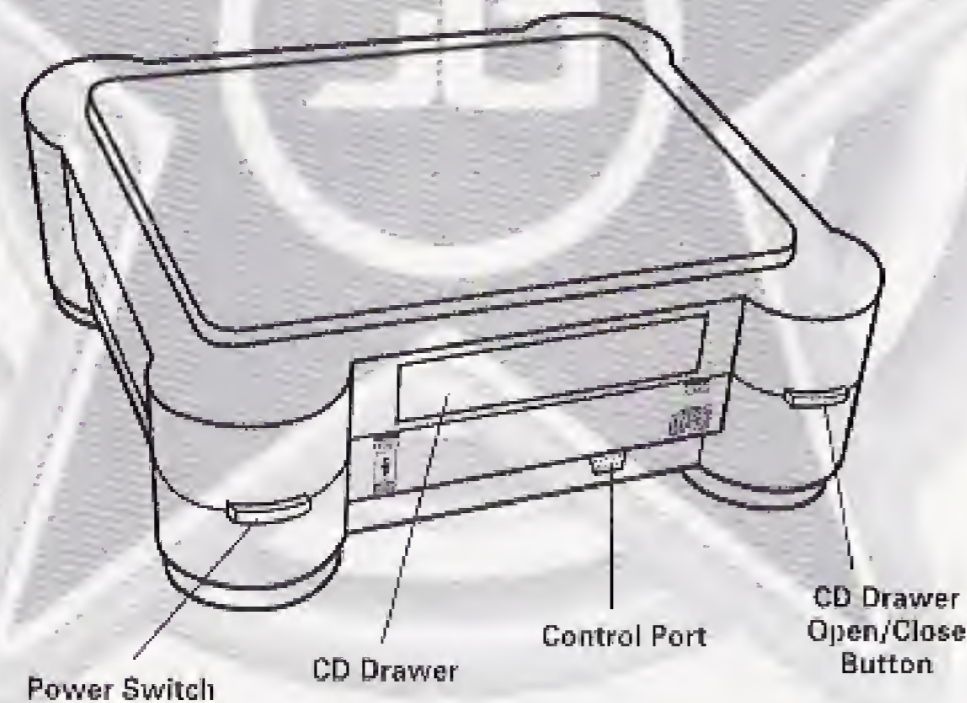

THE STORY

In the nethermost depths of Hell we find El Diablo, sitting miserably pondering the boredom of his existence. Being the supreme ruler of the Underworld is not enough for this bored soul, and he is looking for some new way to improve his state of mind. Turning to his vast array of monitors, on which he watches the world above, he sees something that holds his attention. He watches, growing more and more interested in what he is seeing. A cruel and twisted idea has taken root in those dark and deep recesses of his unfathomable mind. What is it that he is watching? A rock concert. With a guitarist, and in particular, a guitar.

Up in the world of the living we find ourselves at that particular rock concert. A rock concert featuring the talents of one Johnny Bazookatone and his band. Johnny, with his special guitar Anita, is the biggest music sensation in the world right now. His concerts no longer fill stadiums, but whole cities, bridging all generations, races and creeds. He spreads peace, harmony and the love of good music across the globe.

Back in Hell, it is envy that El Diablo feels. He envies the sounds that emanate from Johnny's guitar.

"If I could only get my hands on that magical guitar, then I could make music even greater than this. Then the world would rock to my tunes. What do I mean 'if'? I am the ruler of the depths of Hell, I can do anything I want!" He thought to himself, "Maybe the devil does have the best tunes after all."

With that, El Diablo sent his minions, the Four Impmen of the...the Apocra... Acropo... Apotoli.. whatever, out to kidnap Johnny's guitar, Anita. When the Impmen returned with Anita in their clutches El Diablo grabbed her and tried to play, but he sounded awful. He did not realize that there was no music in his soul and without that, Anita was useless to him. Having tried for some time in vain to play properly, he became incensed with his lack of musical ability.

"WELL, IF I CAN'T PLAY MY MUSIC, THEN THE WORLD WILL HAVE NO MUSIC!!" and with that he sent his minions out to capture the great rock musicians of the era, from Johnny's band. Out they went and kidnapped rock, techno, jazz, and soul geniuses. They grabbed all the living legends in the music industry, but they could not catch Johnny Bazookatone. Johnny saw them coming and realized that these must have been the same guys that stole Anita. Following them to try and find out where they were taking

the rock legends, Johnny knew that they would also lead him to where Anita was being held captive.

As Johnny came to the outer reaches of El Diablo's domain, El Diablo became aware of Johnny's presence and appeared before him.

"I have your precious guitar and I have the greatest living legends in my captivity. Do you think for even one second that you can get to them? They are spread across my entire domain, hidden from you and the world. Leave now or become a prisoner of my dungeons yourself!"

Unimpressed with El Diablo's threats, Johnny nonchalantly grabs his guitar gun, checks his hair and threads, and crosses the threshold of Hell.

Believing that he is unbeatable, El Diablo sits back and smiles in satisfaction as he sees Johnny cross over. His Four Impmen are behind him watching his vast array of monitors, each Imp transfixed on his favorite channel. Imp 1 is a western fan who always carries his six shooters with him. Imp 2 is a Roman film fanatic, forever armed to the teeth with weapons. Imp 3 is a sci-fi freak who can teleport and carries a phaser and wears fake alien ears. Imp 4 is a kung fu film nut who has learned all his martial arts skills from the TV and

thinks he is a Grand Master. These four are dispatched to hinder Johnny's progress as he moves deeper into Hell.

Johnny's journey will take him through an old vacant prison that covers the entrance to Hell through to The Hotel Demonique. He will face a Crazy man in the Attic, the huge Bouncer in the Disco and the Ballroom, and do battle with the Concierge. Then having contracted a dose of food poisoning at the restaurant, Johnny heads to The Hospital, into the surgery and finally battles his way to The Penthouse where El Diablo resides.

Having rescued his musical heroes Johnny must then defeat El Diablo and then and only then he will finally be reunited with his favorite guitar, Anita.

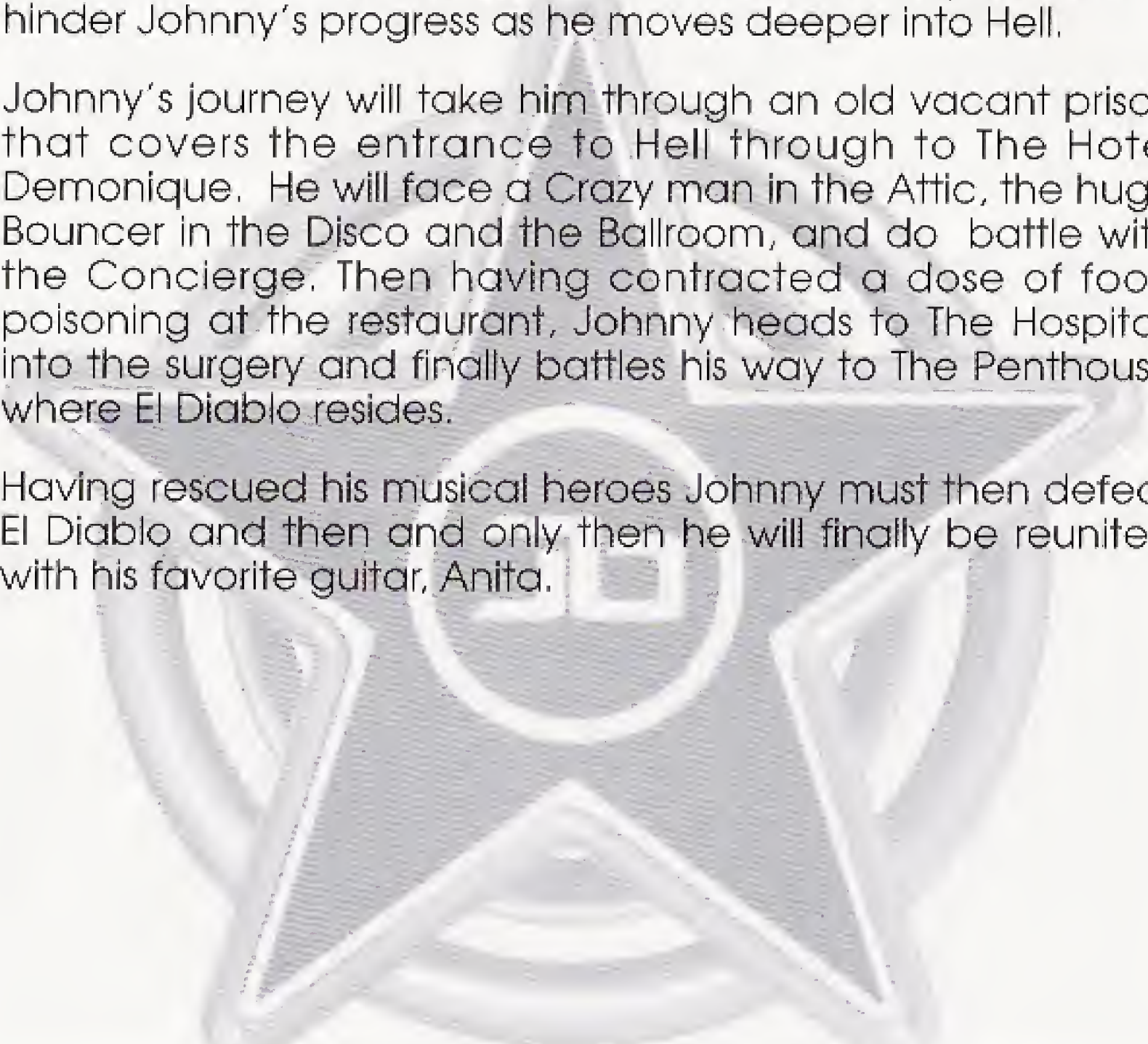

OPTIONS

Music On / Off

Turns music on and off

Sound fx On / Off

Turns Sound fx on and off

Control

There are three preset control settings. Type 0 is the default. Hit button B while Type is highlighted to change to Type 1 or Type 2.

Password

You will be given passwords after completing each level. You will be able to enter your passwords within here. Highlight the password entry part of the screen and hit button B active password entry mode. Then press up or down on the D-pad to select the next slot or a previous slot. When you have entered your password, hit button B and then select Exit. Now select Exit from the Option menu and select Start Game from the Main Menu.

Sound Test

You will be able to play a sound clip from within the game here. Press left or right on the D-pad to select the clip and button B to play it.

CONTROLS

NOTE: THE FOLLOWING CONTROLS ARE THE DEFAULT SETTINGS (TYPE 0) AND MAY BE CHANGED. IF CONTROL TYPE IS CHANGED THE CONTROL BUTTONS IN THE MANUAL WILL BE INCORRECT.

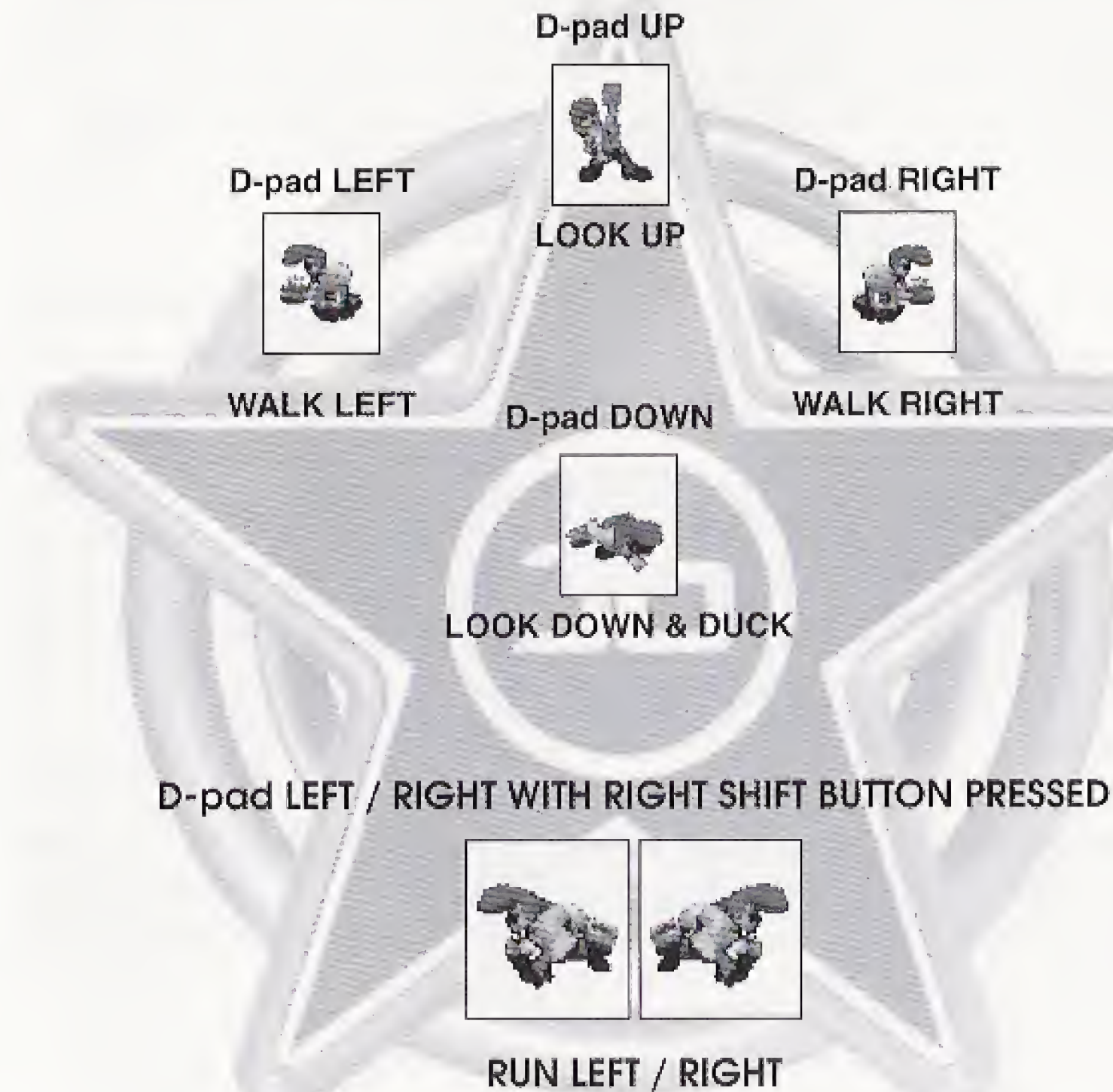
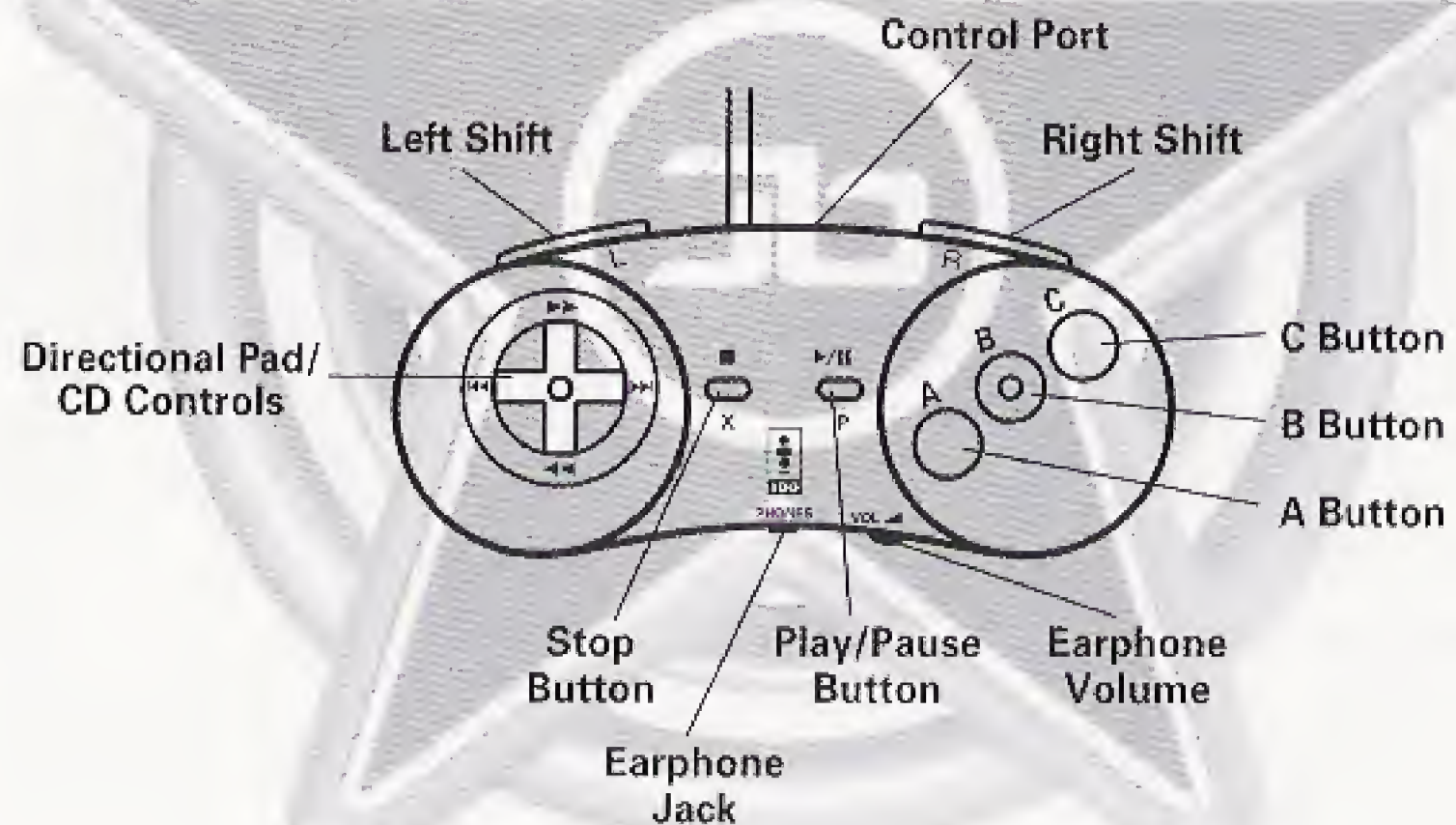

WHEN FALLING OR JUMPING, JOHNNY CAN AIM DOWNWARD AND BEGIN SHOOTING RAPIDLY, BY USING BUTTON A. THIS WILL CAUSE HIM TO HOVER, FALLING SLOWLY. IF YOU ALSO USE YOUR SPIN ATTACK WHILE HOVERING, YOU WILL BE ABLE TO TRAVEL MUCH FURTHER.

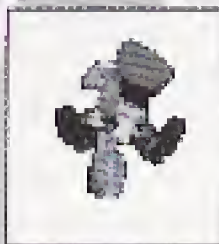

BUTTON A



JOHNNY WILL BEGIN FIRING HIS GUITAR WHEN BUTTON A IS PRESSED. WHEN FIRING, JOHNNY WILL NOT BE ABLE TO WALK OR RUN. THE D-PAD WILL CONTROL THE DIRECTION OF THE SHOOTING.

BUTTON B



IF YOU PRESS BUTTON B, JOHNNY WILL JUMP. JOHNNY'S JUMP HEIGHT IS DEPENDENT ON HOW LONG YOU HOLD THE BUTTON DOWN AND WHETHER YOU HAVE THE RUN BUTTON HELD DOWN.

BUTTON C



THIS IS THE POWER-UP WEAPON. HOLDING THIS AND THEN RELEASING IT WILL FIRE THE POWERED-UP BLAST. THE LONGER YOU HOLD DOWN, THE BIGGER THE BLAST.

LEFT SHIFT BUTTON



SUCK UP / RELEASE OBJECT.

LEFT SHIFT BUTTON & D-PAD UP/DOWN

USE THIS COMBINATION TO ENTER THE ELEVATORS. (CERTAIN LEVELS ONLY).

RIGHT SHIFT BUTTON

THIS WILL MAKE JOHNNY DO A PUNK POGO MOVE SPIN ATTACK. IT WILL ALSO BEGIN THE RUN IF HELD DOWN. IF YOU CAN PRESS THIS IN MID-JUMP JOHNNY WILL RUN WHEN HE LANDS IF IT IS STILL HELD DOWN.

WORLDS



1. PRISON

IN THIS SPOOKY PLACE, DANGER LURKS AROUND EVERY CORNER.

- **PRISON GRAVEYARD**

- SKELETONS 500 POINTS

- **PRISON COURTYARD**

- THUGS TRY AND AVOID THESE GUYS.
- KLAXON FIND SOMETHING TO SHUT HIM UP!
- GUARD DOGS STAY CLEAR, THEY BITE.
- BOUNCING MUSHROOMS THESE ENABLE YOU TO REACH DIFFERENT HEIGHTS. VARIOUS COLORS MAY DO DIFFERENT THINGS.

- **PRISON CELLS**

- MATTRESSES USE THESE TO BOUNCE ON.
- KEYS COLLECT KEYS TO OPEN DOORS.

- **RIVER STYX**

- PIRANHA 200 POINTS
- CHARRON FERRYMAN, YOU MUST PAY YOUR WAY!

- JAZZ GUY
- SUSHI

COLLECT 100,000 POINTS FOR RESCUING.
COLLECT 50,000 POINTS FOR DEFEATING.

2. HOTEL

- **THE LOBBY**

- SUITCASES USE THESE TO BOUNCE ON.
- TELEPORTER THESE TELEPORT YOU FROM PLACE TO PLACE. PLACES THAT YOU MAY NOT BE ABLE TO GET TO NORMALLY.

- ROTATING CHAIRS USE THESE TO MAKE YOUR WAY TO THE TOP.

- ELEVATORS FIRST YOU MUST MAKE SURE YOU ARE STANDING DIRECTLY IN FRONT OF THE ELEVATOR, THEN YOU MUST PRESS UP / DOWN AND THE LEFT SHIFT BUTTON TO ENTER AND GO UP, OR DOWN.

- LAMP 200 POINTS
- VINE 200 POINTS
- THE TICKET 50,000 POINTS
- THE CLOCK TOWER THIS IS THE ENTRANCE INTO THE ATTIC.

- **THE ATTIC**

YOU MAY FIND SOME INTERESTING ITEMS!

- GENERATOR TRY TO START IT. 5000 POINTS
- WINCH THIS IS USED FOR THE ELEVATORS.
- CRAZY OLD MAN COLLECT 50,000 POINTS FOR DEFEATING.

- **THE DISCO**

- BOUNCER YOU NEED TO GIVE HIM SOMETHING, IN ORDER TO ENTER THE DISCO.
- DANCERS BOUNCE ON THEIR HEADS WHEN THEY STOP DANCING.
- CONCIERGE COLLECT 50,000 POINTS FOR DEFEATING.
- SOUL GUY COLLECT 100,000 POINTS FOR RESCUING.

3. RESTAURANT

THIS IS A VERY FAST PACED EXUBERANT PLACE WHERE ANYTHING COULD BE A HAZARD.

- **THE DINING ROOM**

- PIG ONLY SHOOT WHEN HE SMILES! 500 POINTS
- JELLY GOOD FOR BOUNCING ON.
- FLY 500 POINTS

- CHICKEN 500 POINTS
- DUMB WAITER FOOD JUST KEEPS COMING.
- FAT GUY THIS GUY IS ALWAYS HUNGRY!

- **THE VENTS**

NEGOTIATE YOUR WAY AROUND THE MAZE.

- SWITCHES SHOOT THESE FOR A BREATH OF FRESH AIR.

- **THE KITCHEN**

MAKE A SOUFFLE FOR AN UPLIFTING EXPERIENCE.

- BAG OF FLOUR 200 POINTS
- CUP CAKE BOUNCY THINGS.
- EGGS 200 POINTS
- MOUSE TRAP THIS COULD TAKE YOU TO NEW HEIGHTS.
- SAUCEPAN COULD GIVE YOU AN UPLIFTING EXPERIENCE.
- BURGERS USE THESE TO CROSS HAZARDS.
- TOASTER THIS COULD TAKE YOU TO NEW HEIGHTS.
- TELEPORTING TINS PLAY THIS GAME AND WIN BIG.
- HEAD CHEF COLLECT 50,000 POINTS FOR DEFEATING HIM.
- TECHNO KID COLLECT 100,000 POINTS FOR RESCUING HIM.

4. HOSPITAL

- **THE RECEPTION**

YOU USUALLY GET SEEN RIGHT AWAY, BUT NOT HERE. IT IS VERY BUSY AND UNLESS YOU SHORTEN THE LINE, YOU WILL HAVE TO WAIT.

- SICK IMPS MAYBE IF YOU GIVE THESE GUYS SOMETHING, THEY WILL LEAVE. 10,000 POINTS EACH
- SHOCK NURSE 1000 POINTS

- **THE WARDS**

PLEASE BE QUIET, IMPS ARE ASLEEP, BUT THERE MAY BE SOMETHING YOU NEED TO COLLECT!

- VIRUSES THESE COULD CURE, EVENTUALLY!

- **THE MORGUE**

STEREO EQUIPMENT COULD BE USEFUL.

- **THE VENT CHASE**

NEGOTIATE YOUR WAY AROUND THE MAZE.

- **THE LAB**

PROBABLY THE MOST IMPORTANT ROOM, WHERE YOU MUST PERFORM AN IMPORTANT PROCEDURE, BUT BEWARE: YOU MAY GET SQUASHED.

- DOC LUMPHAMMER TRY AND DISTRACT HIM!

- VIRUS MACHINE USE SOMETHING TO CURE WITH THIS MACHINE!

- **THE SURGERY**

YOU MUST TRY AND DEFEAT DOC BUZZSAW THREE TIMES IN HIS VARIOUS GUISES.

- DOC BUZZSAW COLLECT 50,000 POINTS FOR DEFEATING.
- ROCK GUY COLLECT 100,000 POINTS FOR RESCUING.

5. PENTHOUSE

- **THE TV ROOM**

YOU MUST DEFEAT ALL 4 IMPS TOGETHER, IN YOUR MOST CHALLENGING BATTLE YET!

- KUNG FU IMP HE IS A KUNG FU EXPERT. 5000 POINTS
- ROMAN IMP HE IS OBSESSED WITH WAR AND HIS TACTICS ARE SECOND TO NONE. 5000 POINTS
- SCI FI IMP HE IS OBSESSED WITH SCIENCE FICTION. 5000 POINTS
- WESTERN IMP HE IS OBSESSED WITH THE GOOD OLD WILD WEST. 5000 POINTS

• EL DIABLO'S DOMAIN

YOU MUST DEFEAT EL DIABLO IN ORDER TO RESCUE ANITA, YOUR FAVORITE GUITAR.

- EL DIABLO COLLECT 500,000 POINTS FOR DEFEATING HIM.
- ANITA COLLECT 100,000 POINTS FOR RESCUING HER.

GENERAL ITEMS

- SINGLE NOTE 10 POINTS / 1 NOTE (1000 FOR AN EXTRA LIFE)
- TREBLE CLEF 100 POINTS / 10 NOTES (1000 FOR AN EXTRA LIFE)
- BRONZE STAR 1 ENERGY POINT
- SILVER STAR 2 ENERGY POINTS
- GOLD STAR 3 ENERGY POINTS
- RAINBOW NOTE COLLECT 7 IN ANY ORDER FOR 100,000 POINTS OR RIGHT ORDER TO REACH A BONUS ROOM.
- GOOD IMP GIVES YOU A CONTINUE.
- JOHNNY HEAD GIVES YOU AN EXTRA LIFE.
- LEGION ONCE IN RANGE, LEGION WILL HOME IN ON YOU AND START TO BUD. CLEAR ALL THE BUDS OR THEY WILL CHASE YOU. 100 POINTS FOR INDIVIDUAL BUDS.

- KUNG FU IMP HE IS A KUNG FU EXPERT. 5000 POINTS
- ROMAN IMP HE IS OBSESSED WITH WAR AND HIS TACTICS ARE SECOND TO NONE. 5000 POINTS
- SCI FI IMP HE IS OBSESSED WITH SCIENCE FICTION. 5000 POINTS
- WESTERN IMP HE IS OBSESSED WITH THE GOOD OLD WILD WEST. 5000 POINTS
- SMALL IMP THESE GUYS ARE RELATED TO THE FOUR IMPs OF THE APOCALYPSE. 100 POINTS EACH.

CREDITS

PRODUCER

FRANK HOM

TEAM Q A

BRIAN SCHORR, DANIEL WONG
DANNY LAM, MIKE SCHMITT
RICKEY CHOW, STEVE DREO
TOM MARX

TEAM MARKETING

FRANK "SWANKY" ALIZAGA
JOHN LEE
MARYLYNN SLATTERY
SEAN MYLETT

CREATIVE SERVICES

KELLY LINDLAR
LEE WILKINSON
SUTTON TROUT

U.S. GOLD, INC. LIMITED WARRANTY

U.S. Gold, Inc. warrants to the original purchaser that this U.S. GOLD CD is free from defects in materials and workmanship for a period of ninety (90) days from the date of purchase. This U.S. GOLD CD is sold as is without expressed or implied warranty of any kind, and U.S. GOLD is not liable for any losses or damages of any kind resulting from use of this program. U.S. GOLD agrees for a period of ninety (90) days to either repair or replace, at its option, free of charge, any U.S. GOLD CD, postage paid, with proof of date of purchase, at its Factory Service Center.

The limited warranty is not applicable to normal wear and tear. This limited warranty shall not be applicable and shall be void if the defect in the U.S. GOLD CD has arisen through abuse, unreasonable use, mistreatment or neglect. This limited warranty is in lieu of all other warranties and no other representations or claims of any nature shall be binding on or obligate U.S. GOLD. Any implied warranties of merchantability and fitness for a particular purpose, are limited to the ninety (90) day period described above. In no event will U.S. GOLD be liable for any special, incidental, or consequential damages resulting from possession, use or malfunction of the CD.

Some states do not allow limitation as to how long an implied warranty lasts and/or exclusions or limitations or incidental consequential damages so the above limitations and or exclusions of liability may not apply to you. This warranty gives you specific rights, and you may also have rights which vary from state to state.

Our **HELP** Line number is (415) 693-0497. Customer service is available Monday through Friday 9:00 am to 5:00 pm Pacific Time.